

---

## Chapter

<b>ASSEMBLY</b> .....	<b>1</b>
<b>INSTALLATION</b> .....	<b>1</b>
<b>PRECAUTIONS</b> .....	<b>2</b>
<b>FEATURES</b> .....	<b>2</b>
<b>LCD DISPLAY</b> .....	<b>3</b>
<b>KEYPAD</b> .....	<b>5</b>
<b>FUNCTION SETTING</b> .....	<b>6</b>
<b>OPERATION</b> .....	<b>9</b>
<b>WEIGHING UNIT CONVERSION</b> .....	<b>12</b>
<b>APPENDIX 1</b>	
<b>ERROR MESSAGE</b> .....	<b>12</b>
<b>TROUBLE SHOOTING</b> .....	<b>12</b>
<b>APPENDIX 2</b>	
<b>RS-232 FORMAT</b> .....	<b>12</b>
<b>RS-232 OUTPUT SIGNAL</b> .....	<b>14</b>

---

Thank you for your purchase of high precision electronic weighing scale; this scale enables you to measure the quantity, weight and percentage. The scale is easy to operate, precise, stable and with fast display reaction. It is applicable in the electronic, hardware, plastic, medicine, textile and various other industries. It is useful for packaging, inventory and various production and quality control cases.

It could be dangerous by using improper battery or wrong connection of battery.

## ASSEMBLY

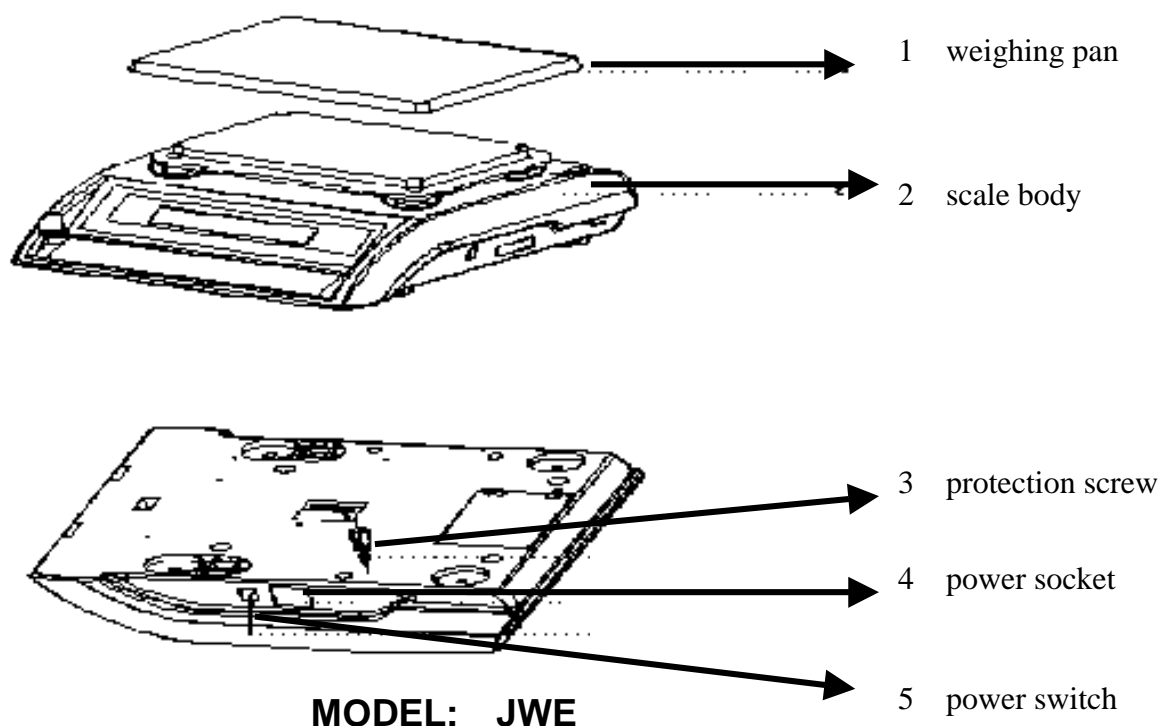

## INSTALLATION

- Put the weighing pan (1) on the scale (2).
- Always lock the protection screw (3) ( 30kg mode without protection screw ) before transportation.
- Remove the protection screw ( 30kg mode without protection screw ) .
- Power socket (4).
- Power switch (5).

---

## PRECAUTION

- Full charge the battery after unpacking the scale.
- Install the equipment on a level and stable surface.
- Do not install the equipment near the air conditioning or vibrating machinery.
- Install the equipment in a temperature environment within -5 —40 , prevent from rapid temperature changes.
- Independent AC outlet for this equipment is recommended, check the voltage before plug in.
- Warm up the equipment for 15 minutes before use.

## FEATURES



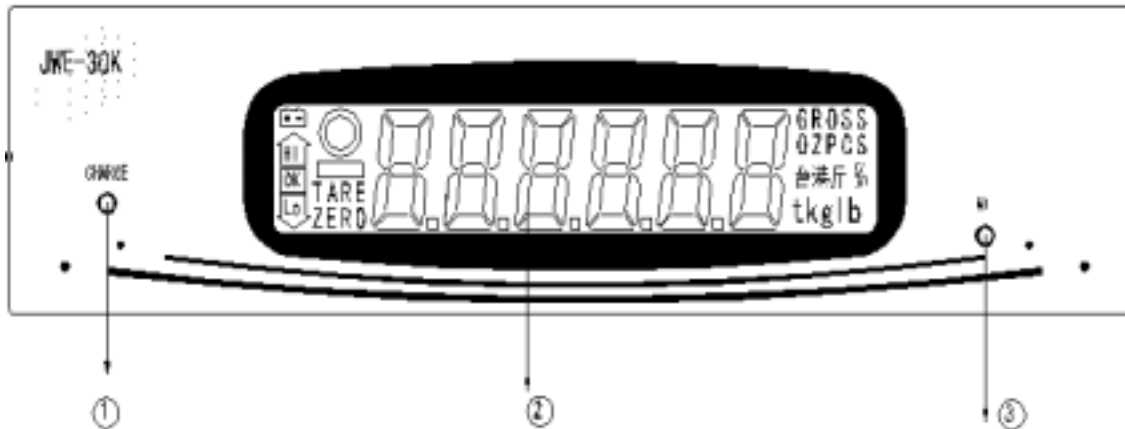

- The microprocessor in this scale features
  - 1) Automatic zero point tracking function.
  - 2) Tare and pre-tare function.
  - 3) HI, LO, OK warning function.
- Easy operating and water-resistant membrane keypad.
- Easy to read backlight LCD display.
- Accumulating function for weight or quantity up to 99 times.
- Counting function is applicable.
- Tare range is unlimited.
- Stainless steel weighing pan is used for long-term operation.

---

## LCD DISPLAY

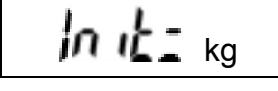
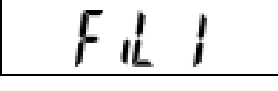
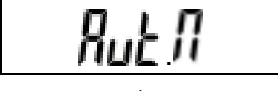
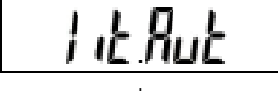
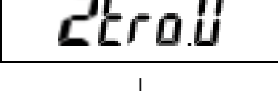
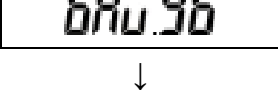
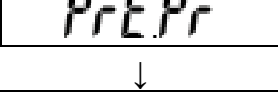
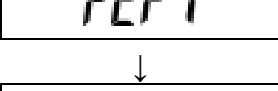
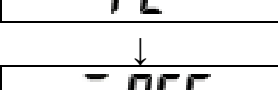
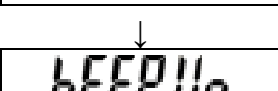

- ① Indicator for battery .Red means battery needs to be charged.  
When the indicator turn green, means that the battery is fully charged.
- ② LCD display.
- ③ Indicator for accumulation

LCD DISPLAY	FUNCTION	SELECTION	PAGE
	Calibration		6
↓			
	Capacity & resolution	30000/6000	6
↓			
	Weigh unit	ON/OFF	6
↓			
	Initial weight unit	Kg / g / lb / lb-oz / pcs / %	6
↓			
	Filter	1/2/4/8	7
↓			
	Auto power off	NO/5/10/30/60	7
↓			
	Backlight	OFF/ON/AUT	7
↓			
	Zero point range	0/1/2/3/4/5	7
↓			
	RS-232 baud rate	2400/4800/9600	7
↓			
	Printing mode	Pr/St/Co	7
↓			
	External device	PC/TPSH/AX/EZ2-S/TDP643	8
↓			
	External device	PC/TPSH/AX/EZ2-S/TDP643	8
↓			
	Memory	ON/OFF	8
↓			
	Beep sound	Un/In/no/Lo	8

---

## KEYPAD

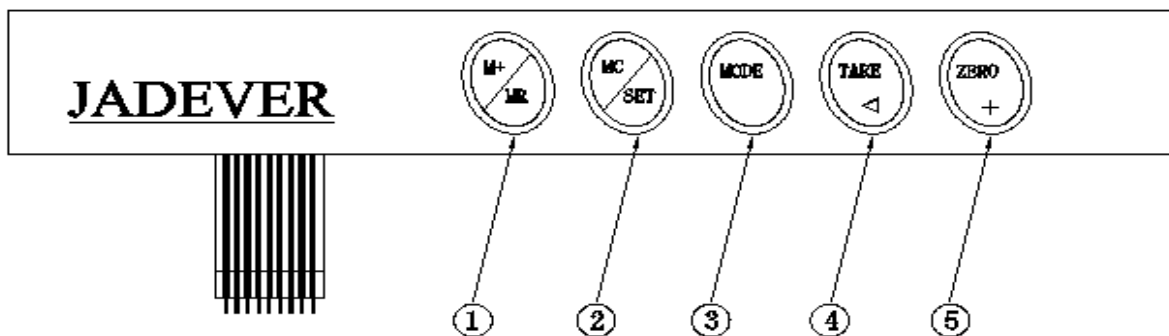

Use this key for accumulation, and to show total accumulation values.



Use this key to set HI, LOW range, and also to clear the accumulation

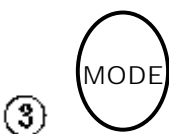

For switching the weighing units.



Press this while tare subject is on the weighing pan.

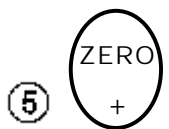

Reset to zero.

**Remark :** ◀ move the cursor to left





+ add



---

## FUNCTION SETTING

Turn the power on while holding down the  key.







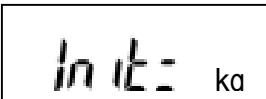



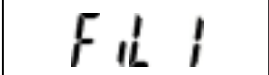

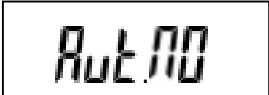
The scale will go into function setting mode and  appears on the LCD display.

- Press  key to switch the function setting.
  - Press  key to select the functions.
  - Press  key to end and save the function setting.
- The LCD display shows  (example: Model JWE-3K)  
– press  key to select the weighing capacity and resolution .  
The capacity and resolution depend on the model of the scale.

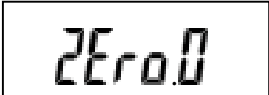

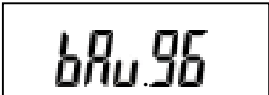
- The LCD display shows   
– press  key to select the applicable weighing unit,  
press  key to enable (ON) or disable (OFF) the weighing unit. \* At least one of the unit has to be used .



- The LCD display shows   
Indicates that “Kg” is the initial weighing unit when power on.

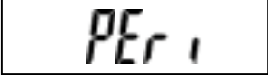
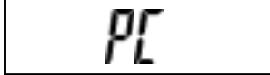

- press  key to change the selection.

- 
- The LCD display shows 
    - press  key to select the filter performance, 1, 2, 4, 8 can be selected.
  
  - The LCD display shows 
    - press  key to select the time of auto power off, 5, 10, 30, 60 minutes and “NO” can be selected.
  
  - The LCD display shows 
    - press  key to select LCD backlight setting, “ON”, “OFF”, “AUT” (backlight >9e) can be selected.
  
  - The LCD display shows 
    - press  key to select zero tracking range, 0-5 can be selected.
  
  - The LCD display shows 
    - press  key to select the transmission rate of RS-232 as 2400, 4800 and 9600 bps.
  
  - The LCD display shows 
    - press  key to select the data transmitting mode.
      - 1) **Prt.Pr** – data sent when key pressed
      - 2) **Prt.St** – data sent automatically when stable symbol shown
      - 3) **Prt.Co** – data sent continuously
-



- 
- When LCD display  and follow by   
press  to choose the external device i.e. : PC、 TP、 SH、 AX、 EZ2-S、 TDP-643.

- The LCD display shows   
– press  key to enable (ON) or disable (OFF) the memory function.

- The LCD display shows   
– press  key to select beep mode.

**Un** – beep sounds when load over pre-set value

**In** – beep sounds when load between pre-set values

**no** – beep sounds when load over pre-set value 1 or under pre-set value 2

**Lo** – beep sounds when load under pre-set value

### Remarks:

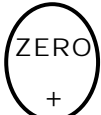
Press  key anytime when a function setting is completed.

This will save the setting and return the scale to normal weighing mode.

### Recharge the battery:

When battery symbol appears on the LCD display, plug in AC power for charging the battery, the indicator will turn red. The charge is complete, when indicator turns into green, (It takes about 8 hours for charging).

---

## OPERATION

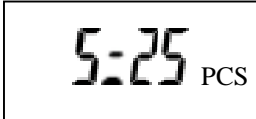

### ◆ Counting

Press  key until LCD display show 

then press  key, the LCD display shows 

press  key select the numbers (25, 50, 100) of sampling, put the samples on the weighing pan, when beep sounds, it is ready for operation.

### ◆ Sampling by percentage

Press  key until LCD display shows ,

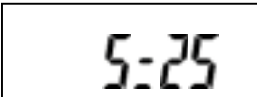

then press  key, the LCD display shows 

press  key select the percentage (25, 50, 100) of sampling,



put the samples on the weighing pan, when beep sounds, it is ready for operation.

---

◆ **Hi/Low setting**

Press  key, then press  key, the LCD display shows

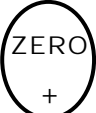
 , press  key to move the blinking “0”, press

 key to enter the limit of the HI weighing value . Press 

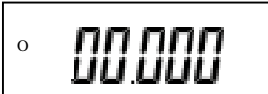
key after that, the LCD display shows  , press

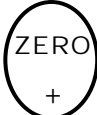
 key to move the blinking “0”, press  key to enter the limit

of the LO weighing value Press  key again, the Hi, Low setting are completed and ready for operation. The value of Low must be set

lower than the value of Hi.



Press  to cancel Hi/Lo check function.

**Remark:**

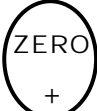
When  setting is set to “ON”, the Hi/Low values will be saved in the memory and can be recalled whenever the scale is on.

The  and  keys are applicable when operation.

◆ **Accumulation**

When there is weight on the pan, press  key to accumulate, the LCD display shows  (example: the weighing

unit is g), the maximum of accumulation is 99 data. When “0” shows



on the display, press  key, the LCD display shows 

the numbers of accumulation. Press  key again, to show the

total accumulated weight. When accumulation is over 99 data, the

LCD display shows  the new data will be disallowed.

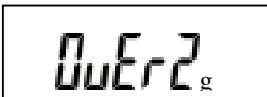
When total accumulation value is over the LCD display range, the LCD

display shows . Press  key to return to normal

weighing mode, or press  key to cancel the accumulation and return to normal weighing mode. It will only clear the accumulation

when the total weight appeared in the display

◆ **Tare**

Place the object on the pan, press key  and the weight will be

tare. The display will show . When you want to

cancel the tare weight, remove the object from the pan, the display will

show the tare weight in negative. Then, press key  the display will return to ZERO.

**WEIGHING UNIT CONVERSION.**

1 lb = 453.59237g

## APPENDIX 1

### ■ Error message

Message	Problem	
Err2	Initial zero point over + 10%	
-Err2	Initial zero point less - 10%	
Err3	Over A/D resolution range FFFFF	
-Err3	Less A/D resolution range - XXXXX	
Err4	EEPROM Chksum error	
Err5	Over load ( max. capacity +9e )	
Err6	Wrong weighing master when calibration	
OuEr1	Accumulation over 99 data	
OuEr2	Accumulation value over display range	
Battery symbol	Low battery	

### ■ Trouble shooting

When	Error message	Trouble shooting
Power on	Err2,-Err2	Check and remove the object from weighing pan or malfunction of LOAD CELL
Power on	Err3,-Err3	Check if A/D or LOAD CELL malfunction
Power on	Err4,	Switch power off and power on again, or do the calibration
Power on	Battery symbol shown	Charge the battery with power on
Normal weighing mode	Err5	Check if weighing object over the capacity+9e
Calibration	Err6	Change weigh master

## APPENDIX 2

### RS-232 OUTPUT FORMAT

**Baud Rate : 2400、 4800、 9600**

**Data Bit : 8**

**Parity : N ( None )**

**Stop Bit : 1**

**Code : ASCII**

**Bit Format :**

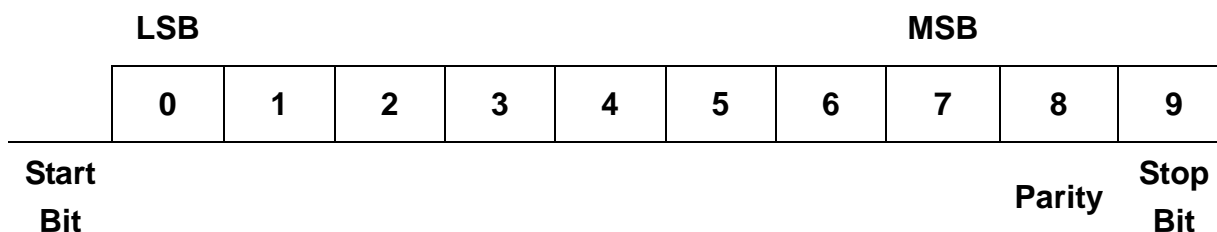



# RS-232 INPUT FORMAT

**Baud Rate** : 2400、 4800、 9600  
**Data Bit** : 8  
**Parity** : N ( None )  
**Stop Bit** : 1  
**Code** : ASCII

**Command on computer** : ' R ' = READ    ' Z ' = ZERO    ' T ' = TARE

## Printer & Printing Format (example: kg)

TP-24	SH-24	EZ2-S	AX-III	TDP-643
T.W.: +0.0000 kg N.W.: +1.6025 kg G.W.: +1.6025 kg	T.W.: +0.0000 kg N.W.: +1.6025 kg G.W.: +1.6025 kg	T.W.:+0.0000 kg N.W.:+1.6025 kg G.W.:+1.6025 kg		

## RS-232 Connector

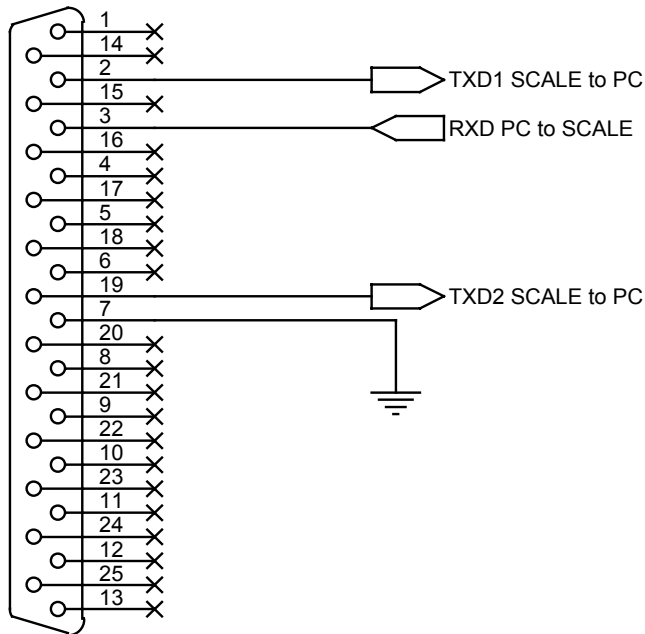

CONNECTOR DB25